

## INSTRUCTIONS FOR USE

### Bladex Stainless Steel Handle

(Model HNDL3)

#### 1. Structure of the Handle

The structure of the Bladex Stainless Steel Handle (HNDL3) is shown in Fig.1.

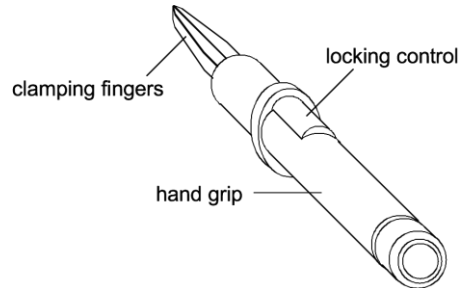

Fig. 1 Stainless Steel Safety Handle

When the handle is inserted into the blade exchanger, turning the grip counterclockwise will make the two clamping fingers open allowing detachment of the blade; conversely, turning the grip clockwise will close the clamping fingers, enabling the handle to firmly hold a blade.

As shown in Fig.1, there are two locking control buttons. In order to open the clamping fingers, these two locking buttons need to be pressed as shown in Fig. 2.

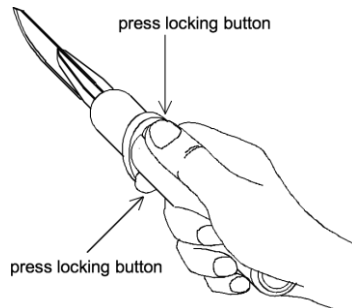

Fig. 2 Press locking buttons to open clamping fingers

#### 2. Changing Blades

\*Please remember that after putting a new cartridge into the device, you must push the sled forward with your hand and release gently in order to place the first blade in the cartridge into its stand-by position. Please refer to our Bladex Safety Exchanger Manual for more information.

Follow these next steps to exchange your blades:

**Step 1** – To discharge a used blade, insert the handle as shown in Fig.3.

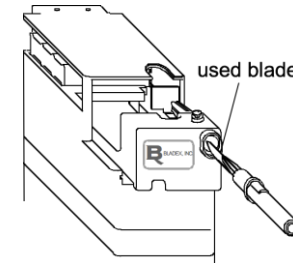

Fig. 3 Step 1: Insert handle with used blade

After the handle is inserted into the device, press the locking switch buttons, then turn the handle counterclockwise as shown in Fig.4.

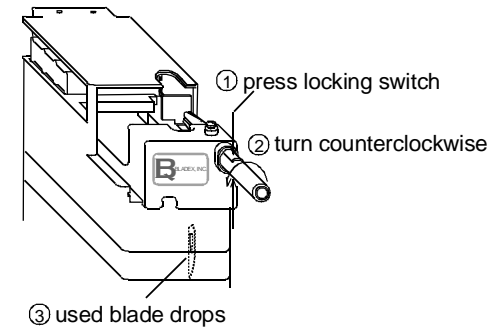

Fig.4 Used blade discharged

Now, the clamping fingers are open and the used blade drops into the sharps container, as demonstrated in Fig. 2.

**Step 2** – To attach a fresh blade, push the sled forward and turn clockwise as shown in Fig.5.

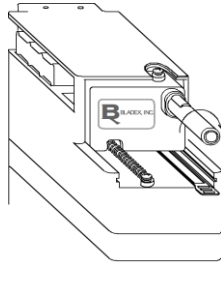

Fig. 5 Attaching a new blade

After the handle is pushed forward and turned clockwise, a new blade is engaged into the handle and two clamping fingers firmly hold it.

**Step 3** – Finally, pull out the handle with a new blade.

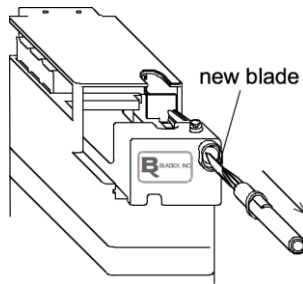

Fig. 6 Pull out the handle with a new blade

Now, the handle will have a fresh blade attached to it, see Fig.6.

### 3. Important Notes:

- (1) Always turn the handle counterclockwise (to open the clamping fingers, see Fig. 7) before pushing the sled forward (step 2).

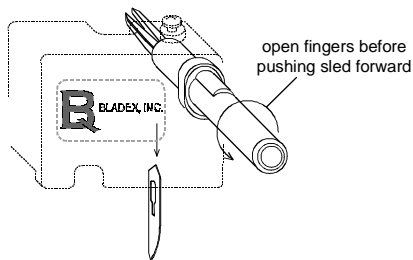

Fig.7 Always open the fingers before pushing sled forward

In other words, once the handle is inserted into the device, you have to turn the handle counterclockwise to drop the used blade before pushing the sled. See Fig.2.

- (2) If the scalpel handle is pulled out without a fresh blade, this usually indicates that the cartridge is empty.
- (3) It is recommended that when an abnormal situation appears, follow these next steps for trouble shooting:
  - (a) Pull out the handle.
  - (b) Take the cartridge out.
  - (c) Make sure the blades are aligned well in the cartridge and reinsert.

### 4. MAINTENANCE

- (1) The handle should be rinsed as soon as possible after use to remove blood, fluid, and tissues. Warm running water is recommended.
- (2) Handles should be thoroughly dried after cleaning and before storing. Prolonged moisture left in the handle can cause rust or corrosion to develop.
- (3) Do not leave the handle in sterilization soak solutions for extended periods, as these solutions tend to be corrosive.
- (4) The scalpel receptacle (where the handle is inserted when changing blades) needs to be replaced or cleaned periodically or whenever it seems excessively contaminated. To take the receptacle off the blade exchanger, unscrew the receptacle from the top of the sled and pull it out of the blade changer.

### CONTACT BLADEX INC.

The technical support group of Bladex can be reached by calling 626-840-7639/626-372-2643 or by email at: [info@bladex.net](mailto:info@bladex.net).

### WARRANTY

Bladex, Inc. warrants its products to be free from defects in material and workmanship for one year, subject to normal usage and care condition, following the date of shipment. This warranty is limited to the original purchaser of the products and is not transferable.

During the one-year warranty period, Bladex will repair or replace, at its discretion, any defective products or parts at no additional charge, provided that the product is returned to Bladex, Inc. Before returning any products for repair or replacement, customers are required to contact the company for a RAN.